

Terminal Unit Systems And ... The Danger Of "Oversizing" Heating Coils

Generally, designers find it prudent to size the heating coils of HVAC air handlers so that they're not only large enough to accommodate design temperature conditions, but weather extremes as well. Incremental heating coil capacity is relatively inexpensive, given the large temperature differences between air and heating water. That means large amounts of extra coil capacity are available with very little added cost.

While oversizing is common practice for heating coils, that's not the case for cooling coils. Much lower temperature differences between the air to be cooled and the chilled water require significantly more coil to obtain additional capacity.

What If The Boiler Return Water's Too Cool?

Consequently, designers often pay little attention to heating coil sizing in many terminal unit designs. As long as there's **enough heating capacity**, the side effects of coil oversizing are largely overlooked. Some system designers have expressed concern about this practice. They argue that an oversized heating coil can cool the returning water to a temperature that's too low to send into a boiler without risking thermal shock.

Certainly, the leaving-water temperature from an oversized coil is cooler than that from a heating coil sized exactly for a specific load. Table 1 illustrates this relationship. The first line shows a coil sized nominally (12" x 54" with 80 fpf) for the 140-Mbh heating duty. The next

two lines show the operating parameters for a 12"-x-54" coil with 132 fins per foot (fpf), oversizing it by 33 percent: i.e. at nominal conditions, the coil delivers 187 Mbh. Notice that throttling the flow through the oversized coil so that it matches the 140-Mbh duty of the 80-fpf coil lowers the leaving water temperature by an additional 46°F to 116°F.

Table 2 views coil performance from a slightly different standpoint, focusing only on the nominally-sized 140-Mbh coil. The first line of the table is identical to the first line in Table 1, showing performance at 100% duty, while the second line shows the **same coil** at 75 percent of its rated capacity. Modulation is accomplished by throttling water flow—in this case, to 3.1 gpm. This time, the coil's leaving-water temperature drops to 122.9°F.

Table 1

Coil Characteristics					Operating Conditions ^a				
Size	Specification ^b	Rating	Duty	Airflow	EAT	LAT	EWT	Flow	LWT
Nominal	12" x 54", 80 fpf	140 Mbh	140 Mbh (100%)			102°F		10 gpm	162°F
			187 Mbh (100%)	3078 cfm	60°F	116°F	190°F	10 gpm	152.7°F
33% Oversized	12" x 54", 132 fpf	187 Mbh	140 Mbh (75%)			102°F		3.8 gpm	116°F

^a EAT, entering air temperature; LAT, leaving air temperature; EWT, entering water temperature; and LWT, leaving water temperature.

^b Type P2 water coil with two rows.

Table 2

Coil Characteristics					Operating Conditions				
Size	Specification ^a	Rating	Duty	Airflow	EAT	LAT	EWT	Flow	LWT
Nominal	12" x 54", 80 fpf	140 Mbh	140 Mbh (100%)	3078 cfm	60°F	102°F	190°F	10 gpm	162°F
			105 Mbh (75%)			91.5°F		3.1 gpm	122.9°F

^a Type P2 water coil with two rows.

What's the point of these comparisons?
It's this:

Whenever the heating output of a coil is modulated by restricting the flow of water, the leaving water temperature will decrease to eventually approach the leaving air temperature. At zero heating capacity, the leaving air and water temperatures are identical. And, incidentally, they're both equal to the entering air temperature.

Design Solutions

Taken to extreme low load conditions, the temperature of returning hot water (less than 90°F) is clearly too low for most hot water boilers. How do system designers deal with this common condition?

Conceptually, there are four ways to accommodate low return water temperature in hot water boiler systems.

Temperature-Controlled Boiler Water Recirculation. This arrangement, shown in Figure 1, is **internal** to the boiler. Controls are also usually part of the boiler, as well. A three-way diverting valve diverts supply hot water from the loads and returns it to the boiler until it reaches a suitably high temperature. This temperature is determined by the boiler manufacturer, and is consistent with

Figure 1
Internal Temperature-Controlled Boiler Water Recirculation

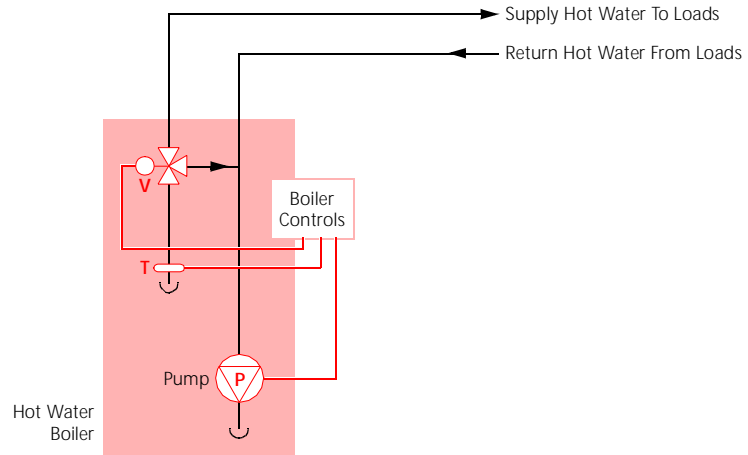

requirements to prevent thermal shock and condensation of flue products.

Three-Way Valves At All Loads. The second method, Figure 2, simply provides three-way modulating (bypass) valves at all heating-load terminals.

In operation, water that bypasses each terminal is returned to the boiler at the supply water temperature. Essentially, this arrangement prevents thermal shock by assuring that the water returned to the boiler isn't too cold. One important exception to this parameter occurs at system start-up. Since the entire water system is cold, the return water

temperature is, too. And, it warms up only after all the water in the system reaches operating temperature.

Pressure-Actuated Bypass Valve. Depicted in Figure 3, a single bypass valve actuated by system pressure replaces all the three-way modulating valves shown in Figure 2. Being pressure-actuated, the bypass valve does not function on the basis of temperature. Thus, the result is somewhat different from the second method. The amount of supply (hot) water bypassed into the return depends on four things:

- The pressure set point of the valve

Figure 2
Three-Way (Bypass) Valves At All Load Terminals

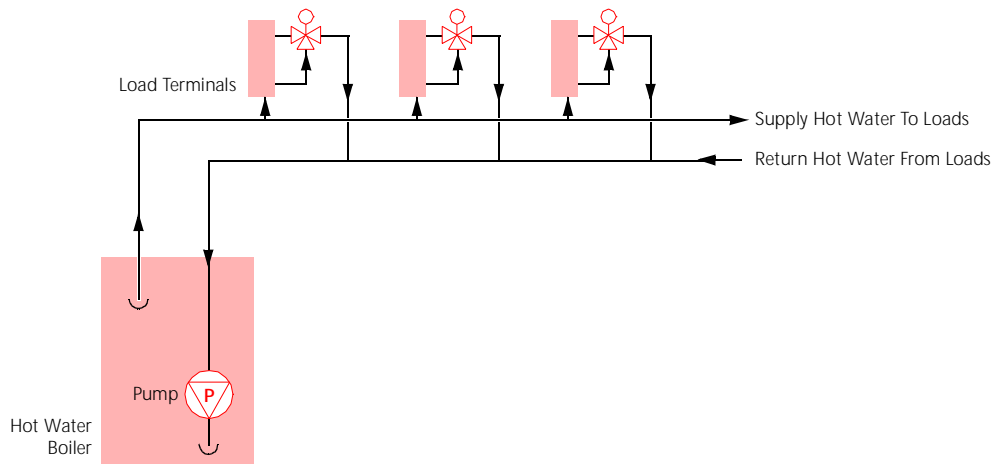
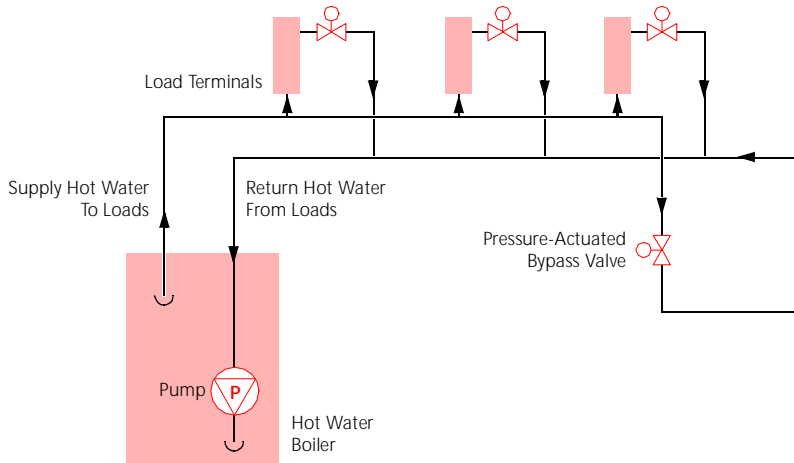

Figure 3
System-Pressure-Actuated Bypass Valve



- The valve's throttling range (i.e. the pressure required to open it)
- The pump's performance curve (i.e. gpm vs. flow)
- The system pressure loss between the pump and bypass valve at design flow

Extra design analysis is required to assure that the pressure-actuated valve effectively maintains the required boiler return water temperature.

Primary-Secondary Pumping System.

The fourth design solution, Figure 4, is really a decoupled pumping scheme. In this arrangement, the primary pump circulates water from the boiler to a decoupler bypass located nearby. If little or no heating load exists, the temperature of the entire loop is essentially the same as the boiler hot water supply temperature. Being hydraulically decoupled from the secondary (distribution) system, flow through the "primary" is independent from anything else in the system.

The secondary (distribution) system is a variable-flow arrangement with two-way modulating valves at the heating terminals. As the system control valves modulate flow, less water circulates through the "secondary." At this condition, the return water temperature

is considerably lower than design and should not be permitted to enter the boiler. Instead, the reduced flow of return water combines with a constant flow of primary boiler water at the primary-secondary interface (bypass) to achieve a higher mixed water temperature.

At zero heating load, this mixture reaches the supply hot water temperature. The result is identical to that of the three-way valve solution described earlier in Figure 2. Adding a valve to the system return avoids the

Figure 4
Primary-Secondary (Decoupled) Pumping System

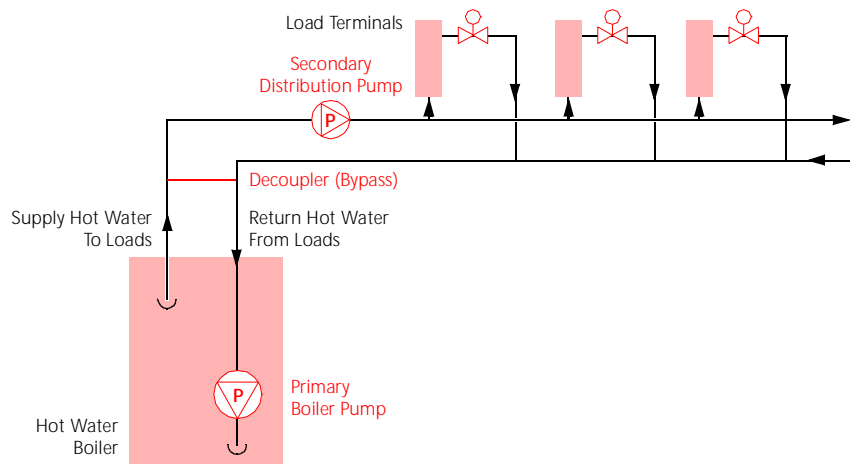

disadvantage of three-way valves at all loads by limiting the amount of water allowed into the boiler until it reaches the proper operating temperature.

Summary

When sizing heating coils:

- Understand that "bigger" doesn't necessarily mean "better." Oversizing heating coils can increase the risk of thermal shock and other boiler-related problems.
- Decide what **system** arrangement best suits the application. ■

By William Landman, now-retired manager of applications engineering, and Brenda Bradley, information designer, The Trane Company.

If you'd like to comment on this article, send a note to The Trane Company, Engineers Newsletter Editor, 3600 Pammel Creek Road, La Crosse WI 54601, or to <http://www.trane.com>.