



Trane VariTrane™ VAV

Terminal Unit



Breakthrough with VAV technology.



VariTrane – leadership redefined

Trane is pleased to introduce a breakthrough in Variable Air Volume (VAV) technology—the new Trane VariTrane™ VAV terminal unit. VariTrane units are manufactured in the most state-of-the-art VAV facility in the world. Proven components, such as the patented Trane Flow Ring and the Trane DDC controller, are used. The most advanced manufacturing techniques in the industry have been implemented to provide an exceptionally rugged and reliable VAV unit. All products are UL® listed for safety and provide proven performance via accepted industry standards like ARI-880 and 885.

Complete VAV control offering

All VariTrane VAV controls are factory commissioned. This means that airflow, temperature setpoints, and addressing are performed in a controlled factory environment. 100% factory-run testing is included to ensure that units arrive and function properly upon job startup. With factory commissioned controls, you have better control over cost and quality. This results in a higher quality installation at a lower cost.

Trane factory-commissioned controls include:

- DDC controller, the VAV Unit Control Module (UCM)—
Optimized performance and integration to Trane Tracer® system

Trane controller communication protocols include:

- Trane proprietary (COMM4), LON™ and BACnet™
- Wireless options for the zone sensor AND unit to unit communication
- Pneumatic controller—Field configurable for reverse- or direct acting thermostats

Factory-installation of customer furnished controls:

Some customers prefer to provide their own controller to be installed in our manufacturing facility. In these cases, Trane will:

- Ensure compatibility with unit relays, fuses, and transformer
- Install the controller, including piping the pressure transducer to the Trane flow ring
- Coordinate with the owner's preferred control vendor



The factory-installed controller option has been available since the early 1990s. It provides unlimited controller flexibility for building owners, and should be considered when Trane controls are not required.

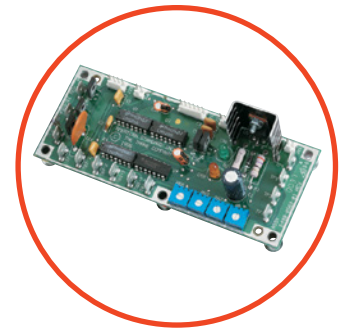
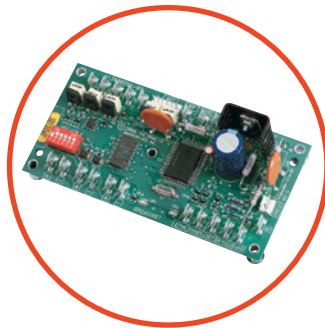

Take a look inside the VariTrane™ unit.

All VariTrane units have the following:

- Trane flow ring for unmatched airflow measurement accuracy
- Heavy gage air valve cylinder
- Interlocking panels which create an extremely rugged unit
- Insulation edges are encapsulated with metal
- UL® and CUL® listing
- Fusing and disconnects (optional)
- Control power transformers (optional)

Single-duct and dual-duct air terminals:

- Single-duct reheat options include water or electric-heating coils
- Unit sizes provide 0 to 8000 nominal cfm
- Access for water coil cleaning
- Factory-commissioned Trane controls
- Factory installation of customer supplied controllers
- Slip and Drive connections as standard

Fan-powered air terminals:

- Parallel intermittent fan and series continuous fan configurations
- Complete reheat options include water or electric-heating coils
- Fan sizes provide 200 to 3000 nominal cfm
- Single-speed motor with SCR is standard for simplified system balancing
- Optional high efficiency ECM motors
- Low-height models for critical plenum requirements

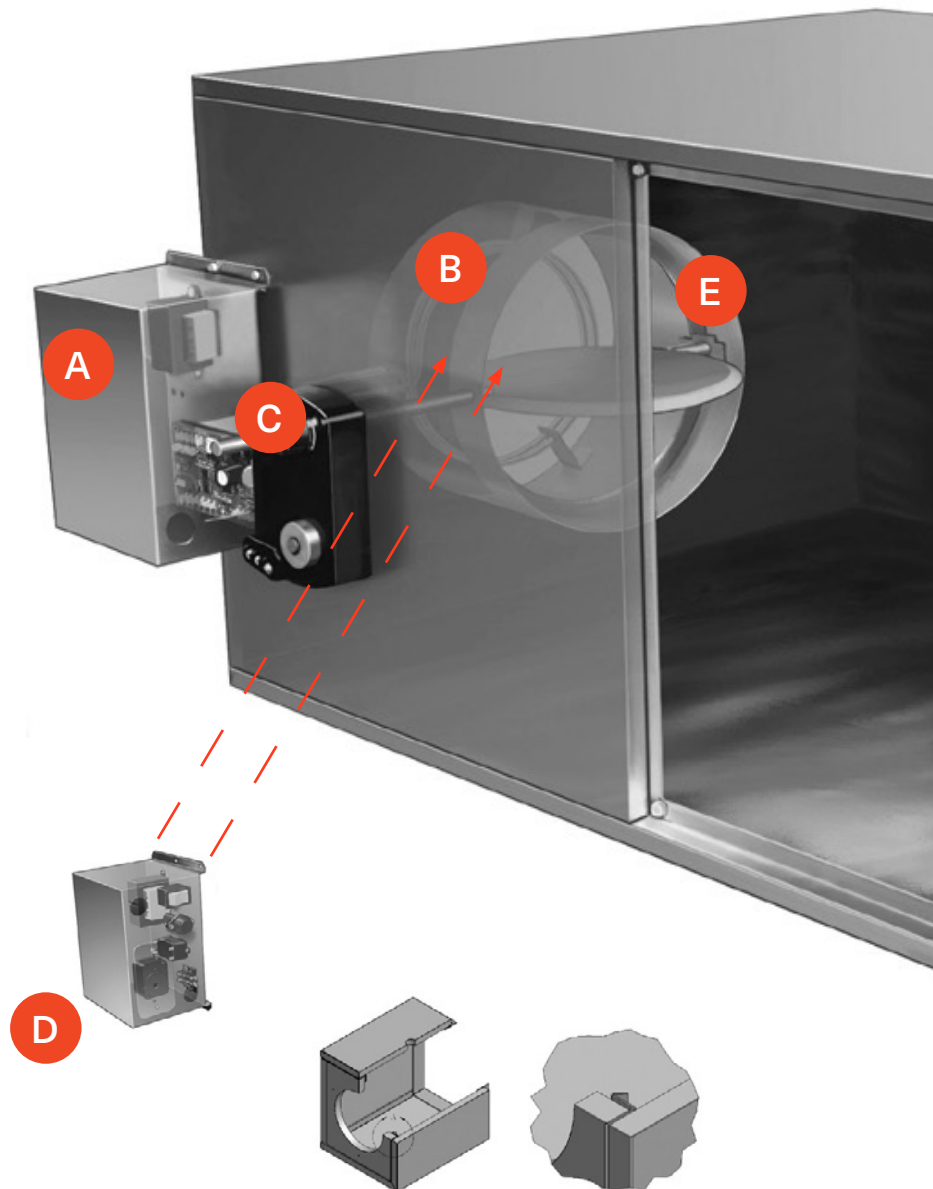

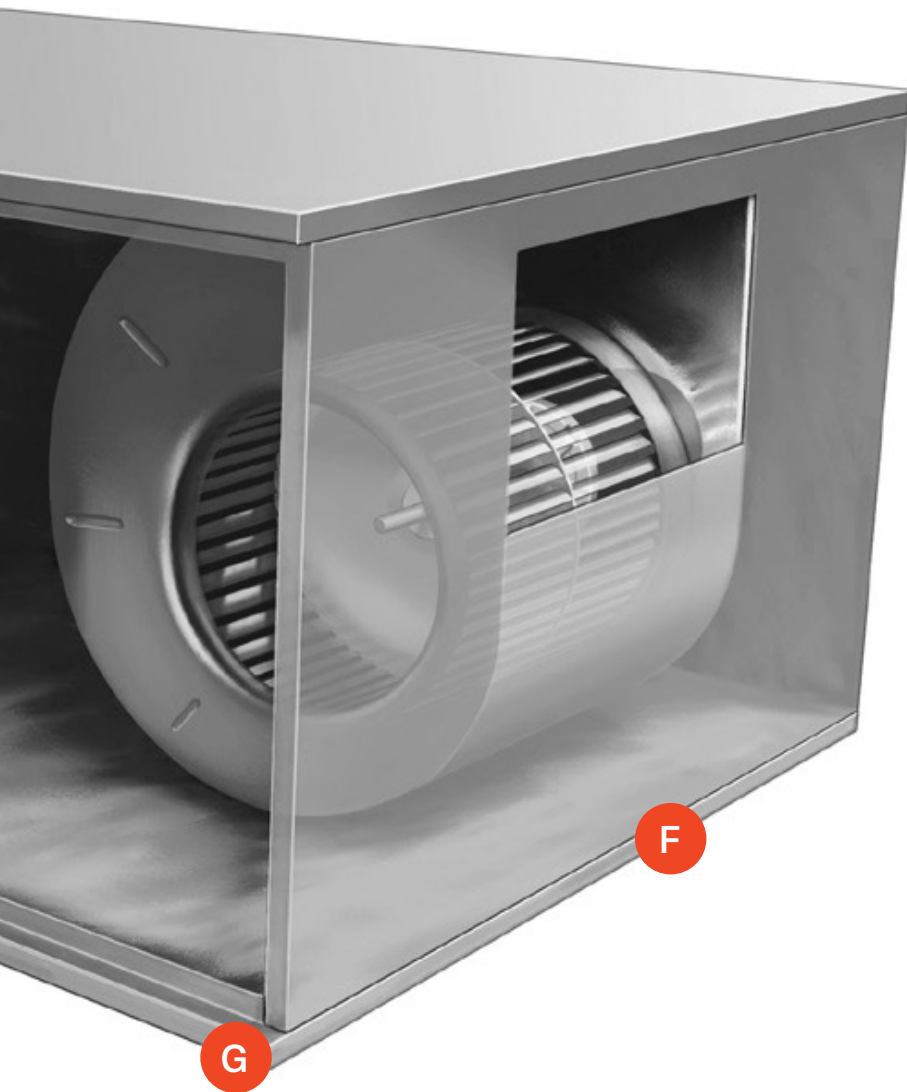

- A Controls** – Trane installs more customer-supplied VAV controllers than any other manufacturer in the industry. For the highest quality and reliability, demand Trane controls.
- B Flow Ring** – The patented Trane flow ring provides unmatched airflow measurement accuracy and unit performance. It is recessed within the 18-gage air valve cylinder for protection during jobsite handling and installation.
- C External Shaft** – Comes with Air Valve Position Indicator for easier service diagnostics. An external shaft also simplifies mounting of all brands of controllers.
- D Fan Controls** – Now comes with a standard SCR or Electrically Commutated Motors (ECM) used for fan-speed control and system balancing.
- E Air Valve** – Designed to limit inlet deformation and provide consistent and repeatable airflow across the flow ring.
- F Interlocking Panels** – Ruggedness and rigidity are assured with Trane's patent pending interlocking panel construction. It creates unmatched unit rigidity.
- G Metal Encapsulated Edges** – All VariTrane Units are complete with encapsulated edges to arrest cut fibers and prevent erosion in the airstream. This raises the bar in the VAV industry.

All about Trane Air-Fi™ Wireless Systems.



Trane Air-Fi Wireless Systems

When using one of the Trane BACnet™ control platforms, optionally the VAV terminal units can be configured from the factory with Trane Air-Fi Wireless technology. This option eliminates the need for, and expense of, a wired communication link between units. It provides wireless unit to zone sensor communication and wireless unit to unit communication.

Fail-Safe Design

Air-Fi utilizes a mesh network. This flexible, resilient system architecture has built-in redundancy to protect against interference and outages. The network automatically re-routes signals around obstacles; it bypasses damaged nodes. The dynamic adaptability of the network ensures reliable communication.

Wide Range Coverage

Each device has four times the number of potential paths out to the network. The 200-foot indoor signal range can extend to half a mile when unobstructed. With multiple paths and a long-range signal, Trane Air-Fi devices can be linked together to create strong, stable, blanket coverage across an entire site.

Performance: Part of the Package

The Trane Air-Fi interface is available as a factory-installed option. It includes a lifetime battery* to deliver a maintenance-free power supply over the life of the system.

*Based on typical indoor operating conditions.

Visit www.Trane.com/AirFi for more information on Trane Air-Fi Wireless Systems.



ZigBee[®]
Certified product

Complete systems include VariTrane™ units.

Energy efficiency

A significant consumer of energy in commercial buildings is heating and air conditioning. One of the most energy-efficient HVAC solutions is the VAV system. This has led to a steady increase in VAV systems over the past several years. VAV systems save significant energy, comply with ventilation requirements, and provide reliable and personalized occupant comfort.

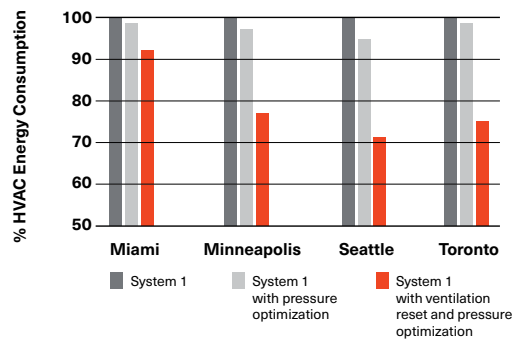

Analysis performed with TRACE® 700 building energy and economic analysis software.

Energy-saving features of Trane VAV terminal units include:

- System strategies like Ventilation Reset, and Static Pressure Optimization, etc.
- Night setback
- Occupied/unoccupied control
- Demand controlled ventilation
- Electrically Commutated Motors (ECM)
- EarthWise™ Systems utilizing low temperature air

To determine the potential energy savings a VAV system can bring to your applications, Trane offers energy modeling programs like System Analyzer™, and TRACE 700™ simulation software.

Doesn't ICS increase VAV system complexity, which may impact reliability?

Not really. Again, most VAV systems are already using communicating controllers on VAV units and air handlers. Control strategies that save energy are pre-programmed into the VAV controller and Trane Tracer™



Integrated Comfort™ Systems (ICS)

Trane Integrated Comfort™ Systems (ICS) combines VariTrane VAV terminal units, Trane DDC controls, and factory commissioning. Trane ICS enables system-level control strategies like Ventilation Reset and Static Pressure Optimization to improve system performance and efficiency. It's like fuel injection in a car's engine. A gravity-fed carburetor will provide gas to your car's engine, but fuel injection does it in the most efficient manner, while boosting horsepower. ICS is just that—a horsepower and efficiency boost for your VAV system!

System, which eliminates field programming errors and complexities. Implementing them only requires minimal time and it actually improves system reliability! All Trane VAV controllers are factory commissioned. This means that all temperature and airflow setpoints are downloaded and 100% run tested in the factory before shipment. You can be assured that Trane DDC systems are the most reliable system available!

Summary

An integrated system is essential for complete building environmental comfort and system efficiency. Through the use of factory-commissioned controllers, and the existing capabilities of the DDC system, additional energy saving strategies can be implemented. At the same time, the system maintains the highest reliability in the industry. Call your local Trane Sales Office for additional details.

Learn more at trane.com



Trane – by Trane Technologies (NYSE: TT), a global climate innovator – creates comfortable, energy efficient indoor environments through a broad portfolio of heating, ventilating and air conditioning systems and controls, services, parts and supply. For more information, please visit trane.com or tranetechnologies.com.

All trademarks referenced in this document are the trademarks of their respective owners.

© 2020 Trane. All Rights Reserved.

VAV-SLB004-EN
06/02/2020